

## Weapon Employment Zone (WEZ) Analysis of the XM-2010 Rifle With Various Ammunition Types

By: Bryan Litz, Applied Ballistics LLC

### Background

The 300 Winchester Magnum is a well established cartridge in the US arsenal. Recent modernization initiatives focused around rifles and ammunition are advancing the effectiveness of this proven cartridge. This Weapon Employment Zone (WEZ) analysis [REF 1] is intended to quantify how the *hit percentage* of the 300 Winchester Magnum is improved thru these modernization efforts. Primarily the ballistic performance of various ammunition types will be evaluated.

### Ammo Types

As part of the 300 Winchester Magnum modernization, rifles have been upgraded and ammunition improvements are being considered [REF 3]. This WEZ analysis will focus on the existing ammo types being considered, as well as some additional variations allowing for newer bullet options that have not been included in any systematic analysis to date. The ammunition types being considered are:

	A191 (MK248 Mod 0)	MK248 Mod 1	230 OTM
<b>Bullet</b>	190 gr SMK	220 gr SMK	230 gr Berger Hybrid OTM
<b>G1 BC</b>	0.523	0.607	0.743
<b>G7 BC</b>	0.268	0.310	0.380
(26" barrel)	3030 fps	2950 fps	2900 fps
(24" barrel)	2950 fps	2850 fps	2800 fps

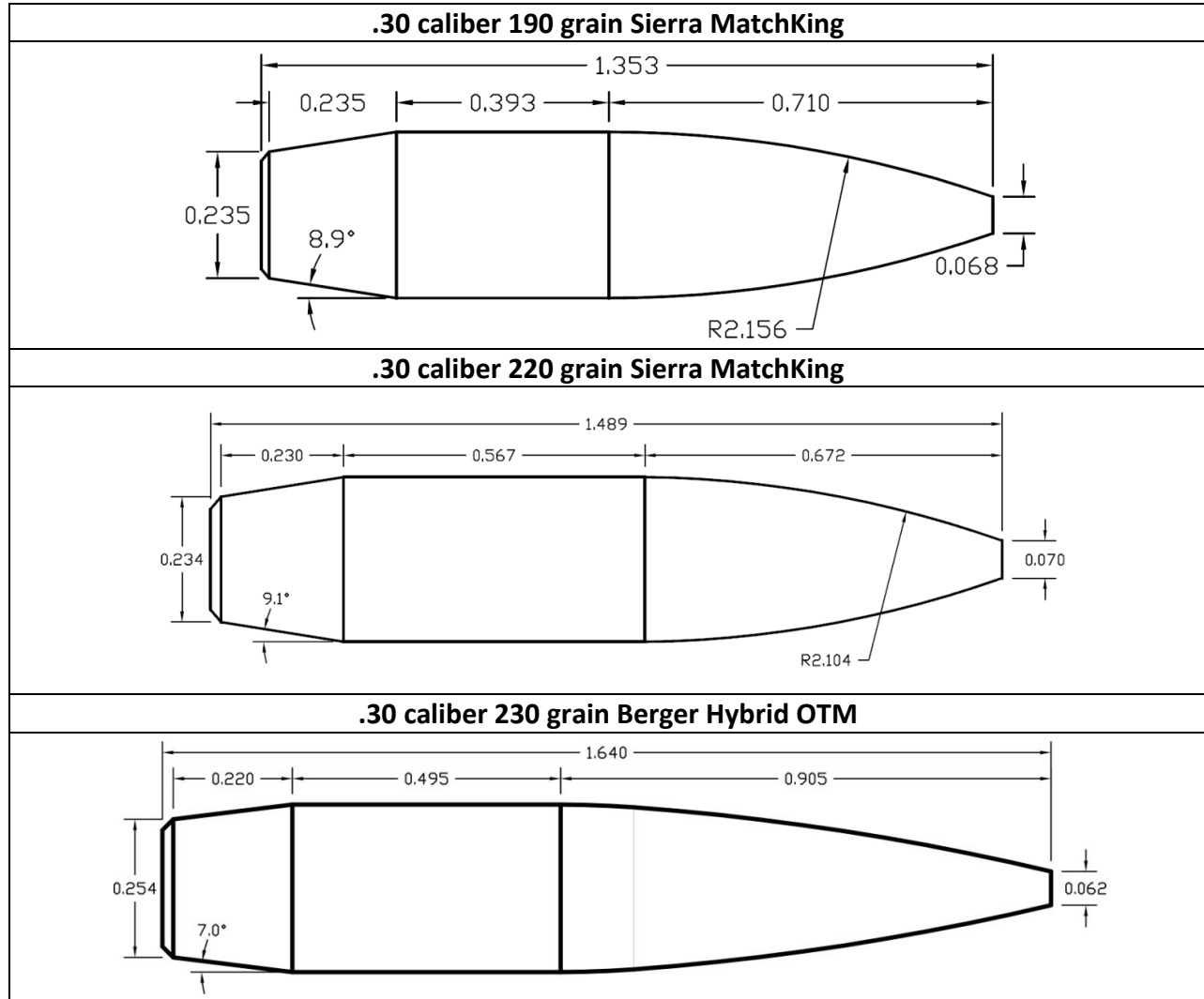



**Table 1. Three types of 300 Winchester Magnum ammunition under investigation for the present analysis. Pictured bullets from left-to-right: 190 SMK, 220 SMK, 230 Berger Hybrid.**

For purposes of this analysis, the muzzle velocities from the 24" barreled (suppressed) XM-2010 will be considered most relevant, and therefore used for all calculations.

The A191 (MK248 Mod0) and Mod 1 rounds are fairly well known and have often been compared against each other [REF 3]. For purposes of the present analysis, an additional ammo type is proposed for comparison, namely 230 OTM. This proposed round will be considered in relation to the other familiar ammo types in several environments to see how the hit percentages compare.

Before proceeding to the actual WEZ hit percentage analysis, Figure 1 shows dimensioned drawings of the 3 bullets under consideration.



**Figure 1. Dimensioned drawings of 3 bullets under consideration for WEZ analysis.**

It's clear from the dimensioned drawings that the 190 and 220 grain SMK's are very similar bullets, with the only major difference being the length of the bearing surface. The relatively blunt nose results in G7 form factors [REF 2] of around 1.06 for both of the SMK's. By stark contrast, the Berger 230 grain OTM has a much longer nose with a tighter meplat diameter and a optimal 7 degree boat tail. The G7 form factor of the Berger Hybrid OTM is 0.91, which indicates 15% less drag than the SMK design. This 15% drag reduction, in addition to being heavier than both of the SMK's results in the Berger Hybrid OTM having a dramatically higher Ballistic Coefficient (BC) and better ballistic performance.

All of the bullets under consideration are fully stable when fired from 1:10" twist barrels.

**Uncertainty Environments**

In order to conduct a complete WEZ analysis, the 3 bullet options will each be evaluated for hit percentage in various uncertainty environments. The intent of the different uncertainty environments is to determine how hit percentage is affected in relation to the variables commonly encountered in real world shooting [REF 1]. Atmospheric conditions will be modeled as ICAO standard sea level values<sup>1</sup>. Other uncertainties will be modeled in 3

	Confidence		
	High	Medium	Low
<b>Cross Wind Estimation</b>	+/- 1 mph	+/- 2.5 mph	+/- 4 mph
<b>Range Estimation</b>	+/- 1 meter	+/- 10 meters	+/- 50 meters
<b>Rifle/Ammo Precision</b>	0.5 MOA	1.0 MOA	1.5 MOA
<b>Velocity Consistency</b>	10 fps SD	15 fps SD	20 fps SD

confidence sets; high, medium and low, according to Table 2.

**Table 2. The uncertainty levels chosen to represent high, medium and low confidence are primarily important for allowing apples-to-apples comparisons among weapon systems.**

The high confidence uncertainty set is intended to model a highly trained shooter with a laser rangefinder,

1/2 MOA rifle, and ammunition loaded with 10 fps Standard Deviation (SD) in muzzle velocity. The medium confidence uncertainty set models a nominal shooter with an average ability to estimate wind speed, compromised use of laser rangefinder, average 1 MOA rifle with typical ammunition having 15 fps SD. Finally the low confidence uncertainty set represents poor wind estimation, MIL'ing targets for range, and below average rifle and ammunition.

Detailed plots and tables of the hit percentage results for each uncertainty environment can be found in the Appendix.

**Modeling**

Of course any calculated hit percentage depends greatly on the size and shape of the target. The target that's modeled for this analysis is the standard IPSC silhouette target shown in Figure 2. Trajectories that intersect the target area are considered hits, those that don't are misses. There is no consideration made for where the bullet strikes the target.

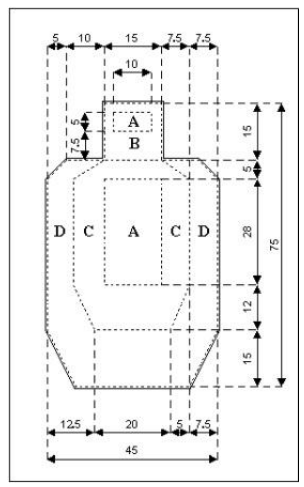

**Figure 2. IPSC target. Dimensions in cm.**

The benchmark Kinetic Energy (KE) indicated on the plots is 1000 Ft-lb. The importance of this metric is debatable, but it's shown on the plots as a reference for comparison.

The benchmark Transonic (TS) speed is Mach 1.2, which equates to 1339 fps in ICAO standard conditions. The transonic speed is indicated on the WEZ plots with a TS, and all values in the hit percentage tables

<sup>1</sup> 29.92 InHg, 59 degrees F, 0% Humidity

that correspond to velocities lower than transonic are printed in gray.

**Results and Analysis - Velocity Retention**

The first element of the results analysis will be retained velocity for the 3 ammo types.

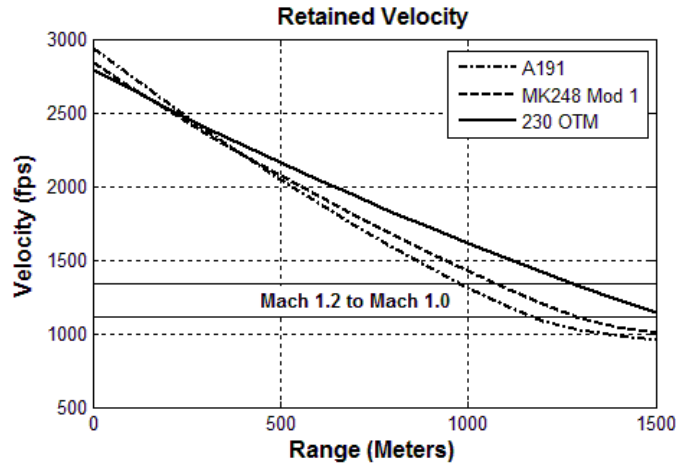

	A191	MK248 Mod1	230 OTM
<b>Muzzle</b>	2950 fps	2850 fps	2800 fps
<b>500 m</b>	2050 fps	2076 fps	2165 fps
<b>1000 m</b>	1315 fps	1430 fps	1617 fps
<b>1500 m</b>	954 fps	1010 fps	1148 fps

**Figure 3. Retained velocity for all 3 ammo types. After 262 meters, the 230 OTM retains the greatest velocity. Upper transonic zone (M1.2-M1.0) is indicated.**

Figure 3 shows a plot of velocity traces from muzzle to 1500 meters with numeric table values at; muzzle, 500 meters, 1000 meters, and 1500 meters.

Since A191 is the lightest bullet, it starts out with the highest velocity. However the heavier 220 and 230 grain bullets quickly catch and surpass the 190 grain bullet in retained velocity. It only takes 162 meters for the 230 bullet to match the retained velocity (2585 fps) of the 220 grain bullet. The 220 grain bullet meets the 190 at 372 meters with a retained velocity of 2260 fps. At 262 meters, the 230 surpasses the 190 grain bullet in retained velocity (2456 fps). *In summary, beyond 262 meters, the 230 grain OTM retains more velocity than both the A191 and MK248*

Retained velocity is an indicator of how flat a trajectory is. Flatness of a trajectory is related to danger space.

Therefore we can say the 230 OTM has the greatest danger space on any sized target beyond 262 meters if all rounds are zeroed at the same range.

In addition to relative retained velocity, it's also interesting to look at where the transonic zone falls for the three ammo types. The WEZ analysis uses Mach 1.2 (1339 fps) as a common transonic speed.

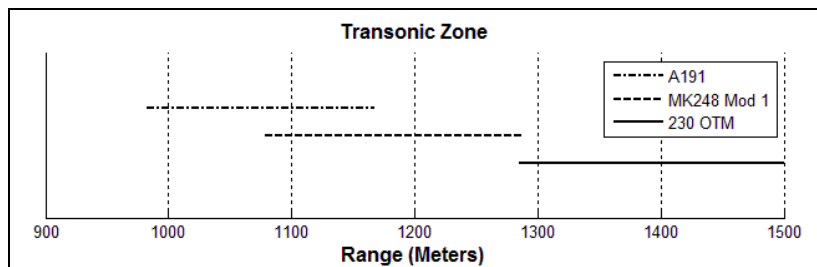

Ammo Type	Upper Transonic (meters)
A191	982 to 1168
MK248 Mod 1	1079 to 1289
230 OTM	1285 to 1500+

**Figure 4. The transonic zones of A191 and MK248 Mod 1 overlap between 982 m and 1289 m. The 230 OTM transonic zone doesn't even begin until 1285 meters and extends beyond 1500 meters.**

However, it can be difficult to predict the exact velocity at which transonic stability effects begin. Figure 3 indicates the zone between Mach 1.2 and Mach 1.0. This is the zone in which one can reasonably expect the onset of transonic instability effects in a sea level environment. Figure 4 shows the ranges that correspond to the upper transonic speed zone (1339 fps to 1116 fps) for each ammo type. It's clear that the 230 OTM pushes the transonic zone much farther than either A191 or MK248 Mod1.

Note that the specific levels of retained velocity are highly subject to atmospheric conditions. The above results are all for ICAO standard sea level conditions. In environments higher above sea level, the bullets will retain velocity much better and the ranges corresponding to transonic zones can be dramatically pushed out. For example, in a density altitude (DA) of 5000 feet, the range at which the 230 OTM encounters Mach 1.2 is extended from 1285 meters to beyond 1500 meters. In other words, *the 230 OTM can remain comfortably supersonic to beyond 1500 meters at DA's of 5000 feet and higher.* Ranges corresponding to Mach 1.2 for A191 is increased from 982 to 1150 meters, and for MK248 Mod1, Mach 1.2 is extended from 1079 meters to 1260 meters.

If the differences in retained velocity appear dramatic, one only needs to refer to Figure 1 which shows the 3 different bullets under consideration. The dramatic difference in bullet design is directly responsible for the dramatic difference in BC and retained velocity.

**Results and Analysis - Kinetic Energy**

As stated in the Modeling section of this report, Kinetic Energy (KE) is a debatable measure of merit to consider in regards to WEZ. A minimum acceptable level of KE is arguable, and the importance of the metric itself is even in question. Nevertheless, KE is included in this analysis for those who wish to consider it as a relative comparison. In the WEZ plots in the Appendix, a KE of 1000 Ft-lb is denoted on the plot with the letters KE.

<b>1000 Ft-lb of Kinetic Energy</b>	
<b>A191</b>	840 meters
<b>MK248 Mod1</b>	1000 meters
<b>230 OTM</b>	1220 meters

**Table 3. Ranges to which each round retains 1,000 Ft-lb of energy.**

Table 3 shows the ranges at which each round's KE is depleted to 1000 Ft-lb in standard sea level conditions. Note that KE depends on remaining velocity which depends on altitude. In other words, at higher altitudes, these ranges can be much greater than those shown in Table 3 for sea level conditions.

**Results and Analysis - Hit Percentage**

All of the conclusions discussed in this section are supported by the graphic and tabular data shown in the Appendix. It's important to remember that the analysis contained here does not account for flawed fire solutions. In other words, average elevation and windage corrections are assumed to be perfect. In reality, this situation typically comes about only after firing a first shot, correcting, and re-engaging the target with a corrected fire solution. This is the only fair way to compare the weapon system itself without confusing the issue with



uncertainties related to calculating a fire solution. It's interesting to study the effect that fire control error has on WEZ, but that is the topic of another WEZ analysis. When the objective is to compare various ammo types for a given weapon system, the comparison should focus only on the ballistic performance differences of the ammo types; which is the sole focus of this analysis.

**High Confidence (Low Uncertainty) Environment**

In a high confidence environment<sup>2</sup> the hit percentage is maximized at each range due to the uncertainties being at a minimum. In this environment, all 3 ammo types maintain a 100% hit percentage out to 800 meters, and the 230 OTM to 900 meters. At 1000 meters, the hit percentage for the A191, MK248 Mod1, and 230 OTM are: 93%, 96%, and 98% respectively. The 5% spread can be more or less important based on the type of analysis being done.

At 1100 meters, the spread from best to worst hit probability (A191 being worst and 230 OTM being best) is 12%, and at 1200 meters the spread is 17%. At 1300 meters and beyond, the 230 OTM maintains approximately 20% advantage in hit probability compared to the A191, and 10% advantage in comparison to the MK248 Mod1.

90% Hit Percentage Hit Confidence	
A191	1027 meters
MK248 Mod1	1095 meters
230 OTM	1185 meters

**Table 4. Ranges to which each round retains 90% hit percentage.**

Table 4 shows the ranges at which the ammo achieves a 90% hit percentage. MK248 Mod1 achieves 90% hit percentage 68 meters beyond A191, and the 230 OTM pushes 90 meters beyond MK248 Mod1, which is 158 meters beyond A191.

Figure 5 shows a graphic illustration of the shot patterns at 1300 meters for the 3 ammo types. At 1300 meters and beyond, there is a 10% improvement in hit percentage between all 3 ammo types. In other words, MK248 Mod1 is 10% better than A191, and 230 OTM is 10%-11% better than MK248 Mod1.

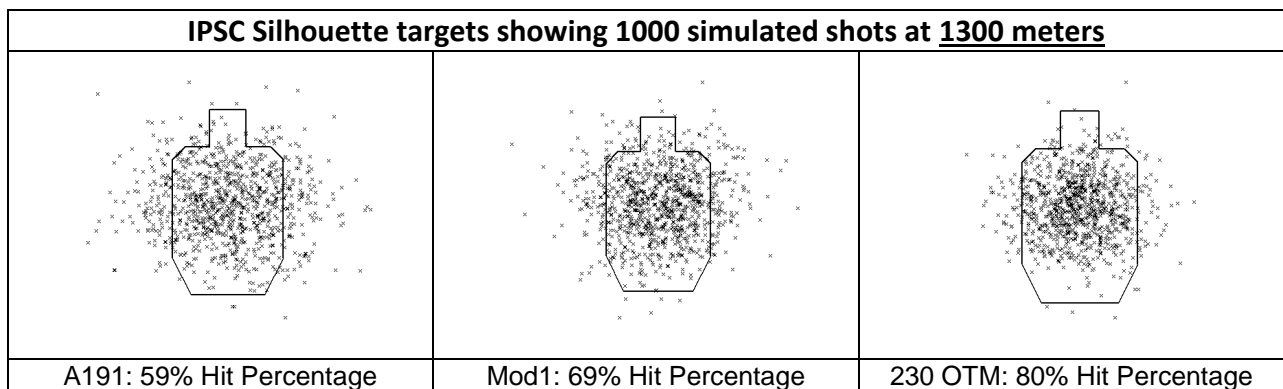

**Figure 5. Graphic illustration of hit percentage on IPSC silhouette target for 3 ammo types in high confidence environment.**

<sup>2</sup> Table 2 shows the exact numeric uncertainties used to model a *high confidence* environment.

**Medium Confidence (Medium Uncertainty) Environment**

The nominal uncertainties which characterize medium uncertainty WEZ are shown in Table 2. The WEZ is somewhat limited by uncertainties considered average for trained shooters and average equipment. In this uncertainty scenario, 100% hit percentage is only maintained out to 500 meters, 600 for the 230 OTM. By 1000 meters, the hit percentage is reduced to 47%, 56% and 70% for A191, MK248 Mod1, and 230 OTM respectively. By 1500 meters, the hit percentages for the 3 ammo types are 18%, 20% and 25%.

<b>90% Hit Percentage Medium Confidence</b>	
<b>A191</b>	688 meters
<b>MK248 Mod1</b>	714 meters
<b>230 OTM</b>	793 meters

The 90% hit percentage thresholds for a medium confidence environment are shown in Table 5. MK248 Mod1 pushes 26 meters past A191, and the 230 OTM pushes 79 meters beyond MK248 Mod1, which is 105 meters beyond A191.

**Table 5. Ranges to which each round retains 90% hit percentage.**

Figure 6 below shows a graphic representation of the hit percentage on the IPSC target at 1000 meters. Note that the vertical dispersion, which is primarily determined by muzzle velocity consistency is similar for all 3 rounds. This is the effect of the 15 fps standard deviation in muzzle velocity used for the medium quality ammunition.

The real difference in the shot patterns is in the horizontal plane, with the higher BC bullet having less horizontal dispersion and more shots on target in the +/- 2.5 mph wind uncertainty.

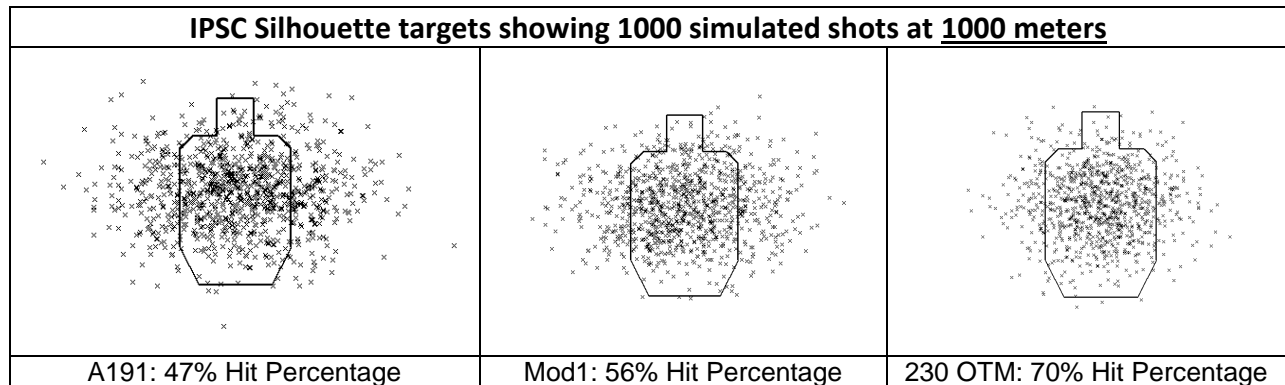

**Figure 6. Graphic illustration of hit percentage on IPSC silhouette target for 3 ammo types in medium confidence environment.**

The shot patterns may not look dramatically different, but the hit percentages are quite striking. The MK248 Mod1 achieves 9% higher hit percentage than the A191, and the 230 OTM achieves 23% higher hit percentage than the A191, and 13% higher than MK248 Mod1 at this range (1000 meters).

**Low Confidence (High Uncertainty) Environment**

The low confidence environment models a shooter with minimal training and shooting ability in addition to ammo of poor consistency. Details of a low confidence environment are listed in Table 2. In a low confidence uncertainty scenario, 100% hit probability is limited to 300 meters for all 3 ammo types. By 1000 meters, the hit percentage is reduced to 31% for A191,

<b>90% Hit Percentage Low Confidence</b>	
<b>A191</b>	502 meters
<b>MK248 Mod1</b>	519 meters
<b>230 OTM</b>	558 meters

35% for MK248 Mod1, and 41% for the 230 OTM. Under such high uncertainties, hit percentages are quite low for all three ammo types.

**Table 6. Ranges to which each round retains 90% hit percentage.**

The 90% hit percentage thresholds for a low confidence environment are shown in Table 6. Table 6 shows that the 90% hit percentage is affected least in the low confidence environment, only being extended from 502 to 558 (56 meters) from worst to best ammo type. This minor increase in 90% range is due to the overwhelming nature of the uncertainties involved in the low confidence environment.

To recap; the high confidence environment allowed for a 158 meter improvement in the 90% range from the worst to the best performer, the medium confidence environment allowed for a 105 meter improvement, and the low confidence environment only nets a 56 meter improvement. This should not come as a surprise; that a highly trained shooter operating in a minimum uncertainty environment can maximize range extension from improved ballistic performance. On the other hand, in environments that have a great deal of uncertainty including lack of rangefinders, and only estimating wind with within +/- 4 mph, the improvement in ballistic performance is much less profound in terms of extending the 90% range. The overwhelming effect of lower confidence environments is a reduction in hit percentage at all ranges.

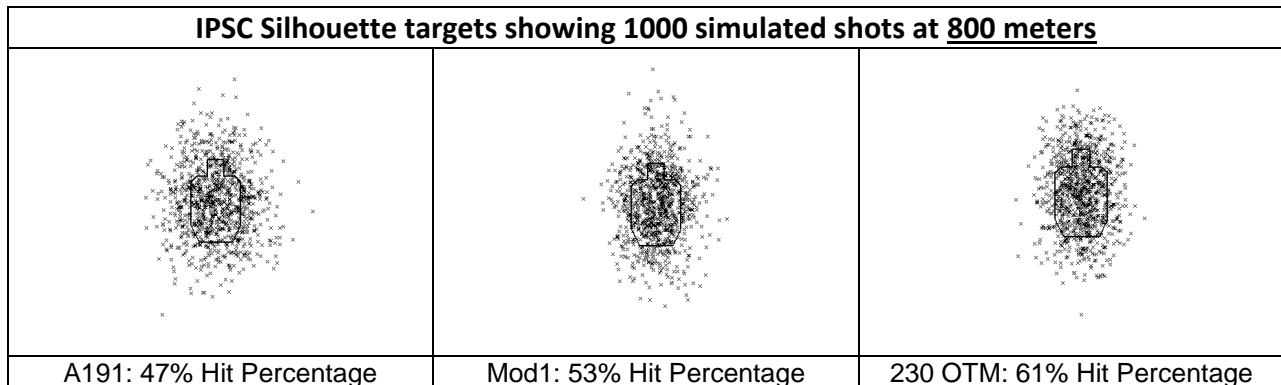

**Figure 7. Graphic illustration of hit percentage on IPSIC silhouette target for 3 ammo types in low confidence environment.**

As Figure 7 shows, the overwhelming component of dispersion is vertical, which is due to the ammo being modeled with 20 fps of standard deviation in muzzle velocity. However, even with this low confidence environment, the higher performance bullets are still able to improve hit percentage to a lesser degree due to resistance to wind deflection.



## Other considerations

Ballistic performance related comparisons are not the only considerations to be made when assessing the suitability of various ammo types. The following sections address some of the components that are not captured in the hit percentage portion of the WEZ analysis, but are none-the-less important considerations.

## Barrel Life

One important consideration is barrel life. One ammo type may appear superior on paper but if useable barrel life is so limited as to keep the rifles in constant rotation to the armory for re-barelling, then the overall effect of the superior ammo type can be more negative than positive.

Accurate formulas for calculating barrel life are not readily available due to the vast array of variables involved, variations in barrel steel, rate of fire effects, etc. In other words, the exact number of rounds a barrel will be *good* for cannot be nailed down precisely, but there are some rules of thumb. In general, heavier bullets moving slower will result in longer lasting barrels than lighter bullets moving faster. Bearing surface length can also affect barrel wear, especially in the throat area where the riflings engrave the bullet. Even though there are no quantifiers, the rules of thumb indicate that the 230 OTM, being the heaviest, slowest MV bullet and having a shorter bearing surface than the 220 SMK, will probably result in the longest useful barrel life out of all 3 bullets considered in this report.

## Terminal Performance

The WEZ assessment is primarily a study of external ballistic performance, and hitting targets. What the bullet does after impacting the target is an issue outside the scope of the main WEZ analysis, but requires consideration in applications where terminal performance is specified.

The 3 bullets under consideration are all of similar construction: open tip, match bullets with relatively thick copper jackets and lead cores. This type of construction produces the most precise bullets available, while achieving desired terminal performance which is characterized by limited penetration at short range (high velocity) and high weight retention and penetration at long range (low velocity) impacts. All 3 of the bullets under consideration share the same materials and construction, and exhibit the same desirable terminal performance attributes.

## Summary

Prior studies have conducted basic comparisons between A191 and MK248 Mod1 ammo types for use in the 300 Win Mag. The results of this WEZ analysis supports prior conclusions that the MK248 Mod1 is superior to A191 in supersonic range, kinetic energy, and hit percentage regardless of the uncertainty environment. In addition to verifying those findings,

an alternative bullet option (the Berger 230 grain Hybrid OTM) was assessed and found to be superior to both A191 and MK248 Mod1 by a substantial margin. The improvement in 90% hit percentage range for the 230 OTM is about the same as the improvement of MK248 Mod1 over A191. With similar terminal performance, and potential for increased barrel life, the Berger 230 grain Hybrid OTM is the clear choice for maximizing hit percentages and extending effective range of the 300 Winchester Magnum cartridge in the XM-2010 platform.

**Appendix**

WEZ plot and hit percentage tables for a high confidence environment.

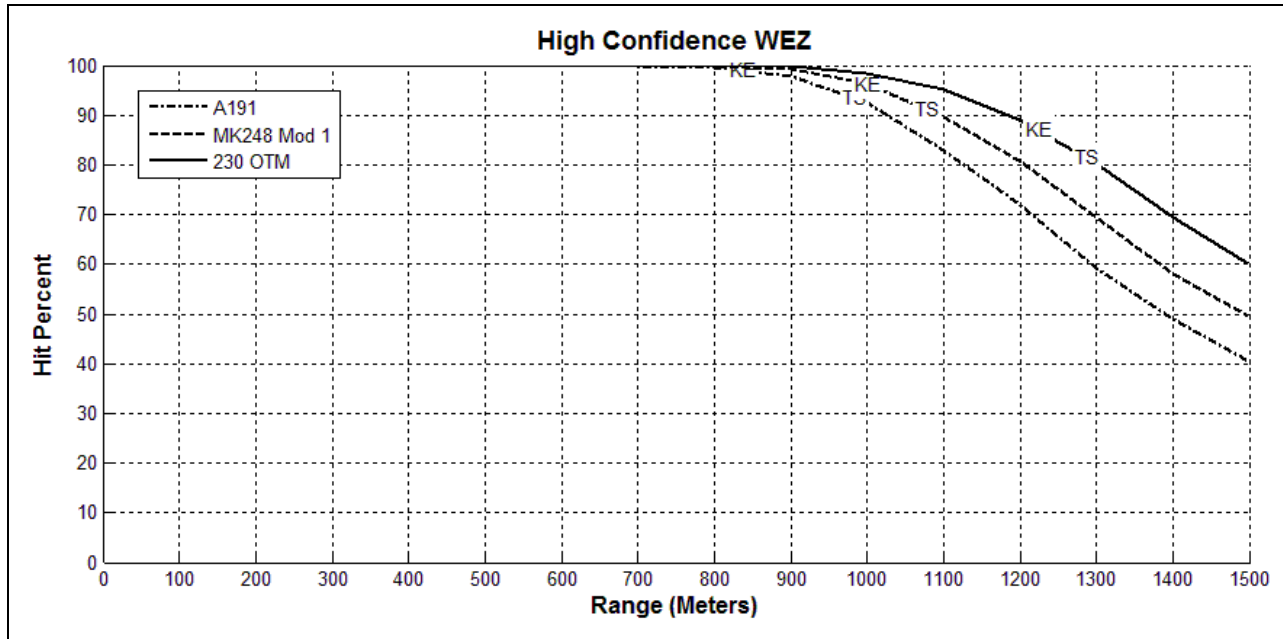

Range Meters	A191	MK248 Mod 1	230 OTM	Criteria
100	100%	100%	100%	This WEZ was run for a high confidence set of environmental variables including the following: Wind determination: +/- 1.0 mph Range determination: +/- 1.0 meters Rifle/Ammo precision: 0.5 moa Ammunition consistency: 10 fps SD
200	100%	100%	100%	
300	100%	100%	100%	
400	100%	100%	100%	
500	100%	100%	100%	
600	100%	100%	100%	
700	100%	100%	100%	
800	100%	100%	100%	
900	98%	99%	100%	
1000	93%	96%	98%	
1100	83%	90%	95%	
1200	72%	81%	89%	
1300	59%	69%	80%	
1400	49%	58%	69%	
1500	41%	50%	60%	

**A1. Hit percentage comparison in high confidence scenario. Note the hit percentage numbers shown in gray are associated with ranges beyond the transonic (TS) range of the projectile.**

WEZ plot and hit percentage tables for a medium confidence environment.

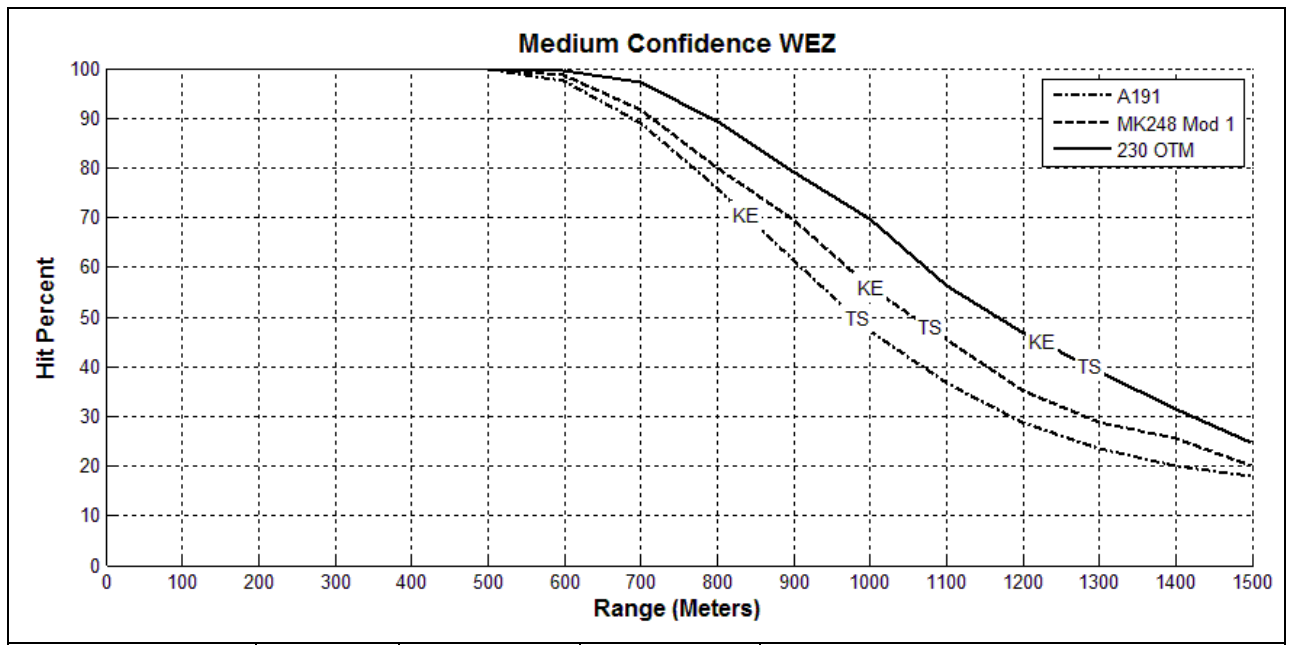

Range Meters	A191	MK248 Mod 1	230 OTM	Criteria
100	100%	100%	100%	This WEZ was run for a high confidence set of environmental variables including the following: Wind determination: +/- 2.5 mph Range determination: +/- 10 meters Rifle/Ammo precision: 1.0 moa Ammunition consistency: 15 fps SD
200	100%	100%	100%	
300	100%	100%	100%	
400	100%	100%	100%	
500	100%	100%	100%	
600	98%	99%	100%	
700	89%	92%	97%	
800	76%	80%	89%	
900	61%	69%	79%	
1000	47%	56%	70%	
1100	37%	46%	56%	
1200	29%	35%	47%	
1300	24%	29%	39%	
1400	20%	26%	32%	
1500	18%	20%	25%	

**A2. Hit percentage comparison in medium confidence scenario. Note the hit percentage numbers shown in gray are associated with ranges beyond the transonic (TS) range of the projectile.**

WEZ plot and hit percentage tables for a low confidence environment.

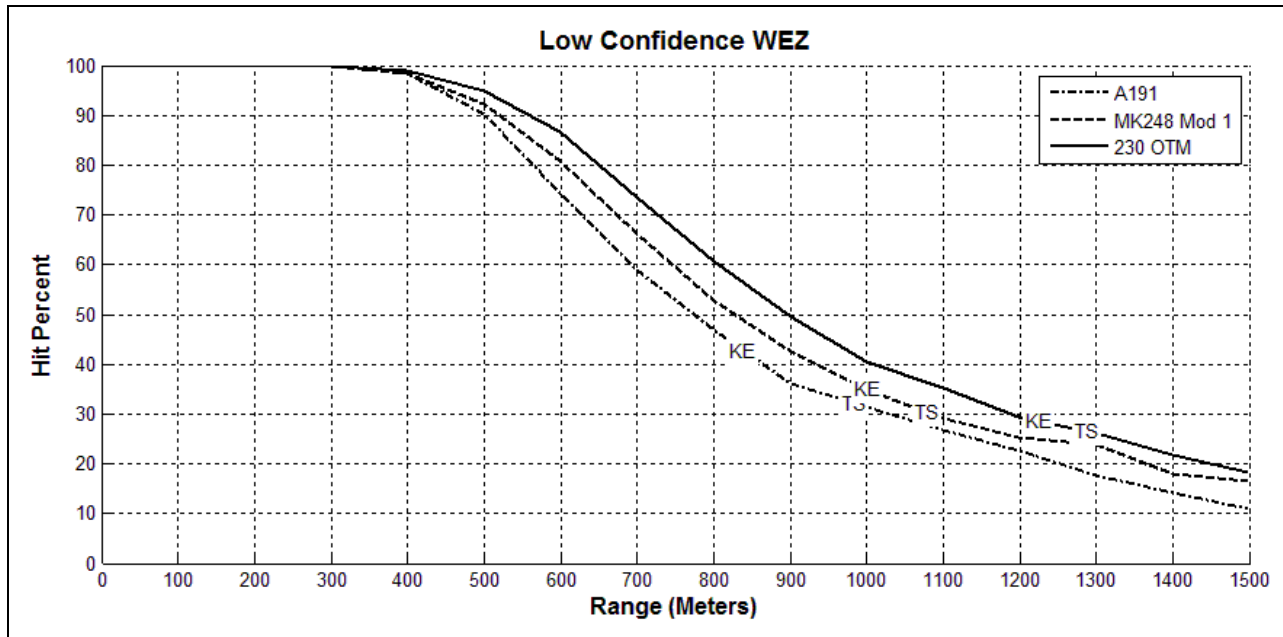

Range Meters	A191	MK248 Mod 1	230 OTM	Criteria
100	100%	100%	100%	This WEZ was run for a high confidence set of environmental variables including the following: Wind determination: +/- 4 mph Range determination: +/- 50 meters Rifle/Ammo precision: 1.5 moa Ammunition consistency: 20 fps SD
200	100%	100%	100%	
300	100%	100%	100%	
400	99%	98%	99%	
500	90%	92%	95%	
600	74%	81%	87%	
700	59%	66%	73%	
800	47%	53%	61%	
900	36%	42%	50%	
1000	31%	35%	41%	
1100	27%	29%	35%	
1200	23%	25%	29%	
1300	18%	24%	26%	
1400	14%	18%	22%	
1500	11%	16%	18%	

**A3. Hit percentage comparison in low confidence scenario. Note the hit percentage numbers shown in gray are associated with ranges beyond the transonic (TS) range of the projectile.**

## References

1. Bryan Litz: "Weapon Employment Zone (WEZ) Analysis"  
(insert link)
2. Bryan Litz: "Applied Ballistics for Long Range Shooting", Second Edition,  
Applied Ballistics, LLC, Cedar Springs, MI, 2011
3. Mr. Chuck Marsh, Mr. Jarod Stoll, Mr. David Leid: "U.S. Navy Small Arms Ammunition  
Advancements", Crane Naval

## Further Reading

1. Robert L. McCoy: "Modern Exterior Ballistics",  
Schiffer Military History, Atglen, PA, 1999
2. Bryan Litz: "Maximum Effective Range of Small Arms",  
*Precision Shooting*, June 2006  
[http://www.appliedballisticsllc.com/index\\_files/Max\\_Effective\\_Range.pdf](http://www.appliedballisticsllc.com/index_files/Max_Effective_Range.pdf)
3. Bryan Litz: "Extending the Maximum Effective Range of Small Arms",  
*Precision Shooting*, July 2006  
[http://www.appliedballisticsllc.com/index\\_files/Extending\\_Max\\_Range.pdf](http://www.appliedballisticsllc.com/index_files/Extending_Max_Range.pdf)
4. Harold R. Vaughn: "Rifle Accuracy Facts",  
Precision Shooting, Inc., Manchester, CT, 2000